



Welding Ovens
Since 1959

User Manual

Portable Welding Rod Ovens
P7, P8, P8M2, P15, P15M2, P16



www.ciaovens.com

Phone +44 (0)1782 566553



Safety

- The portable oven sold with this manual should not be used for any purpose other than that for which it was designed.
- Before operating the oven it is advised that this user manual is read and understood by all users. Accidents and potential risks can be reduced by a thorough knowledge of the ovens operations and ideal working environment.
- It is important that the manual is kept in a tidy condition for any future reference, if a manual is misplaced or damaged, a replacement can be obtained from CIA Ovens.
- Do not damage or remove the safety and rating labels from the oven

All mineral coated electrodes begin absorbing moisture once they are unpacked. Welding with moist electrodes leads to increase arc spatter, undercutting and poor slag removal. Other side effects include porosity, underbead cracking and generally low grade welds. The range of ovens provides facilities for every application where quality welds are required. NOTE: ELECTRODES MUST ALWAYS be removed from their wrappers or packets prior to heating. Failure to do so will result in an increased risk of fire and moisture not being carried off and being re-absorbed into the coating when the electrodes cool.

- In the event of danger such as fire or overheating it is important that the electrical supply be switched off at the first sight of danger
- Take great care when removing electrodes from the oven after heating, wear gloves and take care, the oven may still be very hot.
- Undergo all operations with general due care and attention





Electrical Information

To ensure that your CIA product is electrically safe, it is important to ensure that a suitably rated fuse is used in the plug when using the oven. By following simplistic electrical codes of practice such as Ohms law and the Power Triangle, determining the correct and appropriately rated fuse is used. Below is a explanation of these electrical theories:

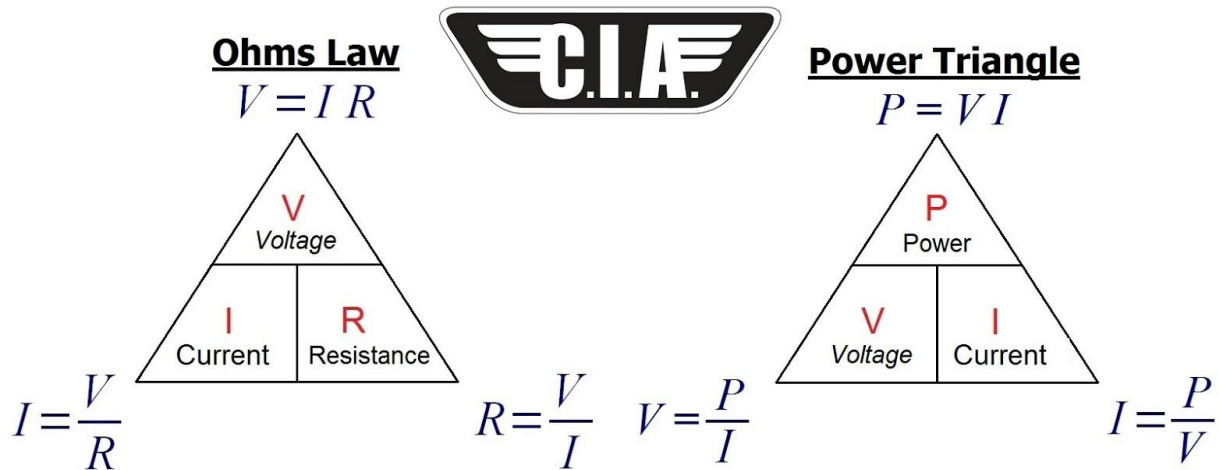

Oven Model	Voltage (Volts)	Power Output (Watts)	Current (Amperes)	Resistance (Ohms)
P7	24	150	6.25	3.84
	48-85	150	3.125	15.36
	110	150	1.36	80.66
	240	150	0.625	384
P8/P15	48-85	300	6.25	7.68
	110	300	2.73	40.33
	240	300	1.25	192
P8M2/P15M2	48-85	275	3.24	26
	110	275	2.5	44
	240	275	1.15	209
P16	110/240 Dual	300	2.73 (110V) 1.25 (240V)	40.33 (110V) 192 (240V)



Oven	Capacity	Max Temp	Power Output	
P7 24V, 48-85V, 110V, 240V	9 KG	110° C	150Watt	 A green, rectangular oven with a carrying handle on top and a metal stand at the bottom. The CIA logo is visible on the front panel.
P8 48-85V, 110V, 240V	7KG	190° C	275Watt	 A tall, green, rectangular oven with a carrying handle on top. The CIA logo is visible on the front panel.
P8M2 48/85V, 110V, 240V	9KG	190° C	275 Watt	 A tall, green, rectangular oven with a carrying handle on top. The CIA logo is visible on the front panel.
P15 48-85V, 110V, 240V	11KG	200° C	275 Watt	 A tall, green, rectangular oven with a carrying handle on top. The CIA logo is visible on the front panel.



<p>P15M2 24V, 48-85V, 110V, 240V</p>	<p>15KG</p>	<p>190° C</p>	<p>275 Watt</p>	 A tall, narrow, green rectangular heater with a black handle on top and a control panel on the front.
<p>P16 110V/240V Dual Voltage</p>	<p>14KG</p>	<p>320° C</p>	<p>300 Watt</p>	 A wider, green rectangular heater with a black handle on top, a latch on the front, and the CIA logo on the side.



Installation

The Oven is shipped in a durable cardboard box to provide protection during shipment, wherever possible try to re-use the box or dispose it in an environmentally responsible way.

Great care should be taken with the ovens location and operating environment, please consider the following to ensure your CIA Portable Oven is located safely:

- Where possible place the oven on flat or level ground, avoid slanted, uneven and undulating surfaces, or any environment in which the oven could become unstable or fall over completely.
- Ensure the ovens power cable is not subject to high tension, always provide some slack
- Do not place the oven in places where it could be subject to draft or high levels of humidity.

Once the oven is placed in its optimal location adhere to the following guidelines for an efficient and safe installation:

- Check that the mains electrical supply is suitable for the oven. The voltage and power requirements are given on the rating plate located next to the mains supply cable.
- Connection to the mains electrical supply should be made via an appropriately fused plug for a portable oven.
- It is recommended that the earth lead is connected with provision for some `slack` so that, in the event of the cable coming under stress the earth wire is the last to be affected

The colour coding of the mains supply is as follows

Single Phase

<u>Wire Colour</u>	<u>Connection</u>
Brown	Live
Blue	Neutral
Green/Yellow	Earth



Operating Instructions

Portable Quiver P7

Starting the oven:

1. Ensure the oven is sitting steadily
2. Open the door and fill with desired quantity of electrodes & close door firmly
3. Securely plug the oven into a suitable power source and switch on the supply
4. The oven will now start to heat up to maximum temperature, it may be necessary to turn on the neon switch (where fitted)

Portable Rod Oven P8, P8M2, P15, P15M2

Starting the oven:

1. Complete steps 1-3 from P7 startup instructions
2. Turn the thermostat bezel to the desired temperature, a 'click' can be heard as the thermostat is switched on.
3. The oven will now heat up to its target temperature set by the operator, the neon indicator will go out when the oven reaches its set target.

Portable Rod Oven P16

Starting the oven:

1. Ensure that the voltage selector switch is set to the desired operating voltage.
2. Complete steps 1-3 of P7 startup instructions.
3. Turn the thermostat bezel to the desired temperature, a 'click' can be heard as the thermostat is switched on.
4. The oven will now heat up to its target temperature set by the operator, the neon indicator will go out when the oven reaches its set target.



Operating Recommendations

Electrode Stabilization

The temperature at which basic electrodes should be re-dried depends on the level of hydrogen considered permissible in the deposited weld. Recommended re-drying temperatures to reduce hydrogen content to various limits are as follows:

<u>Type</u>	<u>Temperature after Opening</u>	<u>Typical Reconditioning environment</u>
Cellulose	40°C-50°C	Not Recommended
Iron Powder M.S	40°C-50°C	80-100°C 30 Minutes
Titania	40°C-50°C	80-100°C 30 Minutes
Low Hydrogen/ Low Hydrogen High Tensile	120°C-150°C	80-100°C 90 Minutes
Stainless	120°C-150°C	80-100°C 90 Minutes
Inconel, Monel, Hard surfacing	65°C-95°C	80-100°C 30 Minutes
Brasses, Bronzes	65°C-95°C	Not Recommended

Note: It has been suggested that the presence of even the smallest amount of hydrogen can adversely affect lamellar tearing. Therefore where lamellar tearing is a problem re-drying at 450c for 60 minutes is often carried out.

Prolonged Drying Periods

Some fabricators who are concerned to obtain the highest possible radiographic standards of weld metal have developed a technique whereby, the electrodes, on completion of drying, remain in the oven at full temperature until they are required for use. The technique is very effective in providing thoroughly dry electrodes but may tend to decrease the strength of the coating. It is suggested, therefore, that the maximum drying period for various re-drying temperatures should be set as follows:

<u>Drying Temperature</u>	<u>Maximum Period at Temperature</u>
150 Celsius	72 Hours
250 Celsius	12 Hours
450 Celsius	2 Hours



Maintenance

Planning of routine maintenance is an essential part of ensuring your CIA Ovens product is kept in the best possible condition and to ensure continual, efficient operation. Always conduct maintenance when the oven is out of service. Always ensure that the power cable is in good condition, free from breakages or tearing. NOTE: Check that the oven is cool before commencing maintenance work.

HEATED QUIVER P7

Element and Switch Replacement

1. Switch off and isolate the quiver from the mains supply.
2. Retain all screws.
3. Turn the quiver and remove the four screws securing the base panel.
4. Remove the two screws from the element anchor.
5. Remove the element and replace as necessary.
6. To replace switch, note connections, remove leads from the terminals and replace the switch.
7. Reassemble in the reverse order.

HEATED INSULATED QUIVER P8, P8M2, P15 & P15M2

Thermostat replacement

1. Switch off and disconnect the oven from the electrical mains supply.
2. Retain all screws, nuts etc. for re-assembly.
3. Stand the oven on its front edge and remove the four screws securing the base panel.
4. Remove the thermostat knob & the bezel retaining screws.
5. Note the electrical connections before removing any terminations.
6. Remove the wires from their terminals.
7. Remove the thermostat.
8. Re-assemble in the reverse order.

Element replacement (P8 & P15)

1. Carry out paragraphs 1 - 4 of thermostat replacement.
2. Note the position of the element terminations and remove the Fastons.
3. Remove the two screws retaining the Element assembly.
4. Remove the element assembly and replace with new.
5. Reassemble in the reverse order

Element replacement (P8M2 & P15M2)

1. Carry out paragraphs 1 - 4 of thermostat replacement.
2. Note the position of the element terminations and remove the Fastons.
3. Un tighten the nut retaining the heat sink and element assembly on the back of the inner body.
4. Remove the heatsink clear of the element
5. Remove the element assembly and replace with new.
6. Reassemble in the reverse order.



PORTABLE DRYING ROD OVEN P16

Thermostat replacement

1. Switch off and disconnect the oven from the electrical mains supply.
2. Retain all screws, nuts etc. for re-assembly.
3. Stand the oven on its front edge and remove the four screws securing the base panel.
4. Remove the thermostat knob & the bezel retaining screws.
5. Note the electrical connections before removing any terminations.
6. Remove the wires from their terminals.
7. Remove the thermostat.
8. Re-assemble in the reverse order.

Element replacement

1. Carry out paragraphs 1 - 4 of thermostat replacement.
2. Note the position of the element terminations and remove the nuts and washers.
3. Remove the two screws retaining the Element assembly.
4. Remove the element assembly and replace with new.
5. Reassemble in the reverse order.

Extraordinary maintenance

Periodically check the quality and connection of electrical wires and components, and replace where necessary. In the case of any further problem, please contact your dealer or directly to CIA Ovens who are on hand to help resolve your problem.



CIA P7

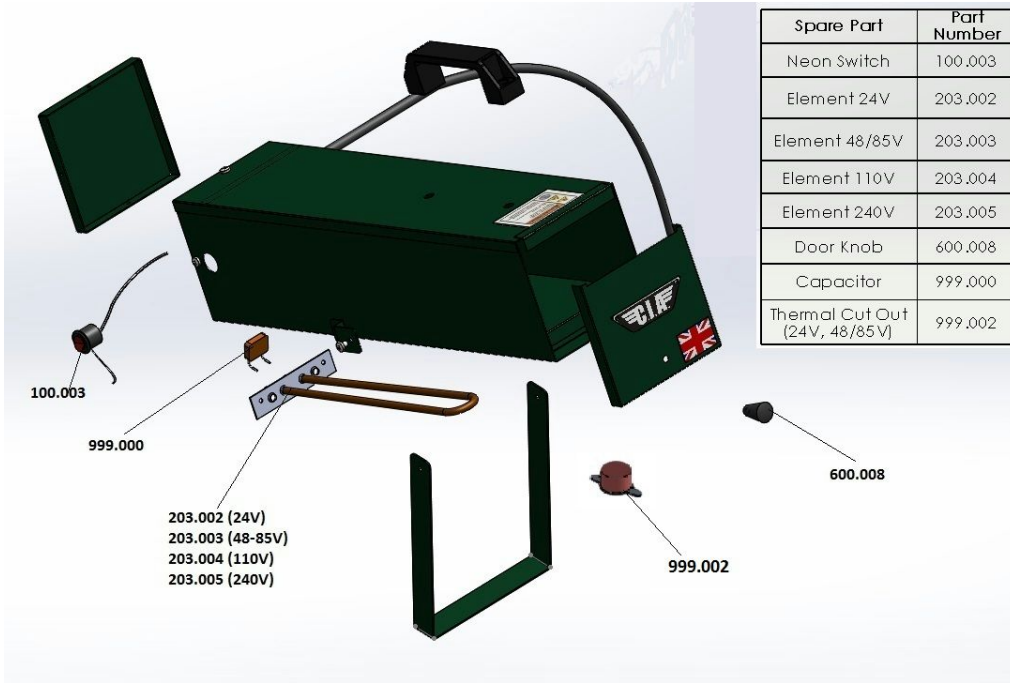

Spare Part	Part Number
Neon Switch	100.003
Element 24V	203.002
Element 48/85V	203.003
Element 110V	203.004
Element 240V	203.005
Door Knob	600.008
Capacitor	999.000
Thermal Cut Out (24V, 48/85V)	999.002

Neon Switch (Where Fitted)

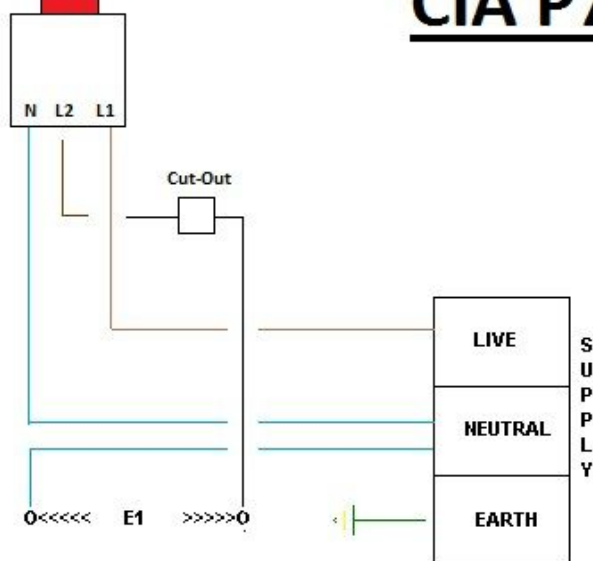

CIA P7



CIA P8

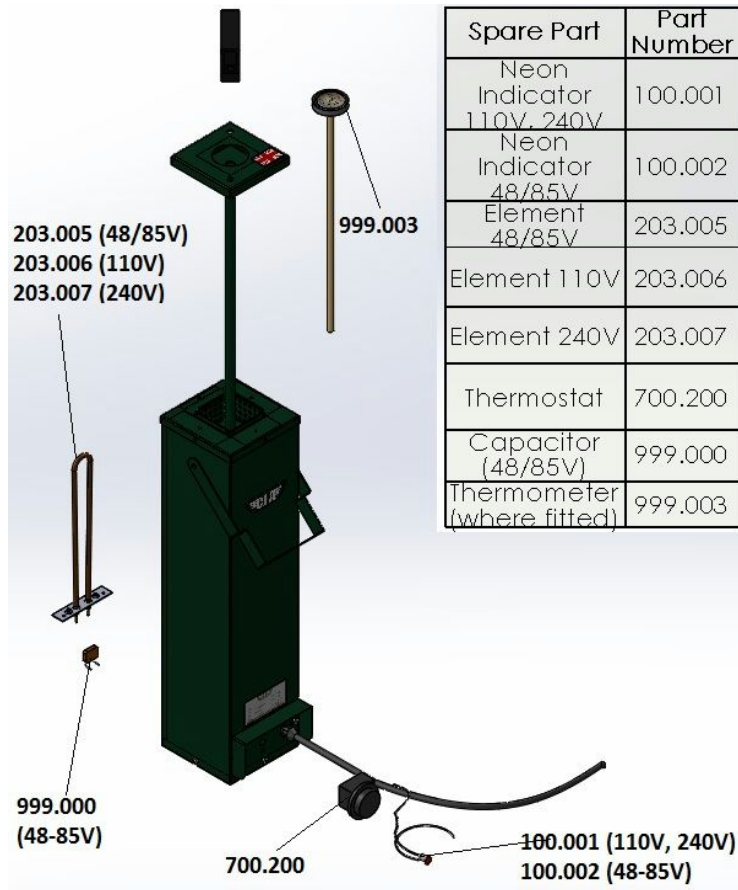

Spare Part	Part Number
Neon Indicator 110V, 240V	100.001
Neon Indicator 48/85V	100.002
Element 48/85V	203.005
Element 110V	203.006
Element 240V	203.007
Thermostat	700.200
Capacitor (48/85V)	999.000
Thermometer (where fitted)	999.003

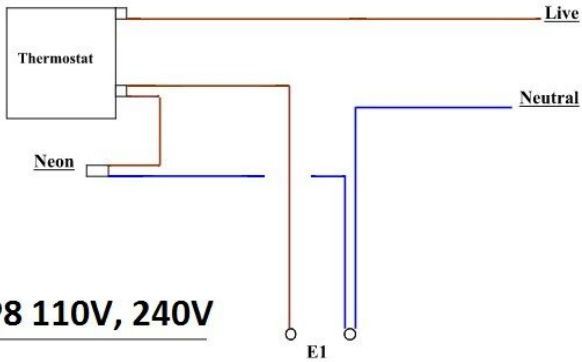

CIA P8 110V, 240V

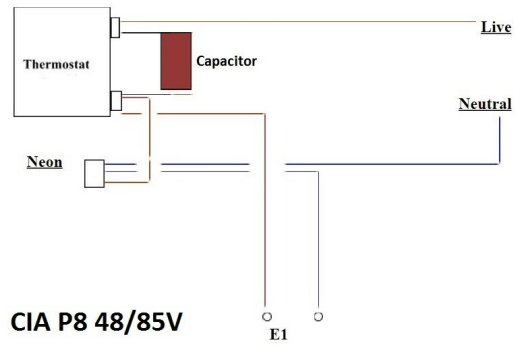

CIA P8 48/85V

48/85V Versions are fitted with a capacitor between the thermostat terminals



CIA P8M2

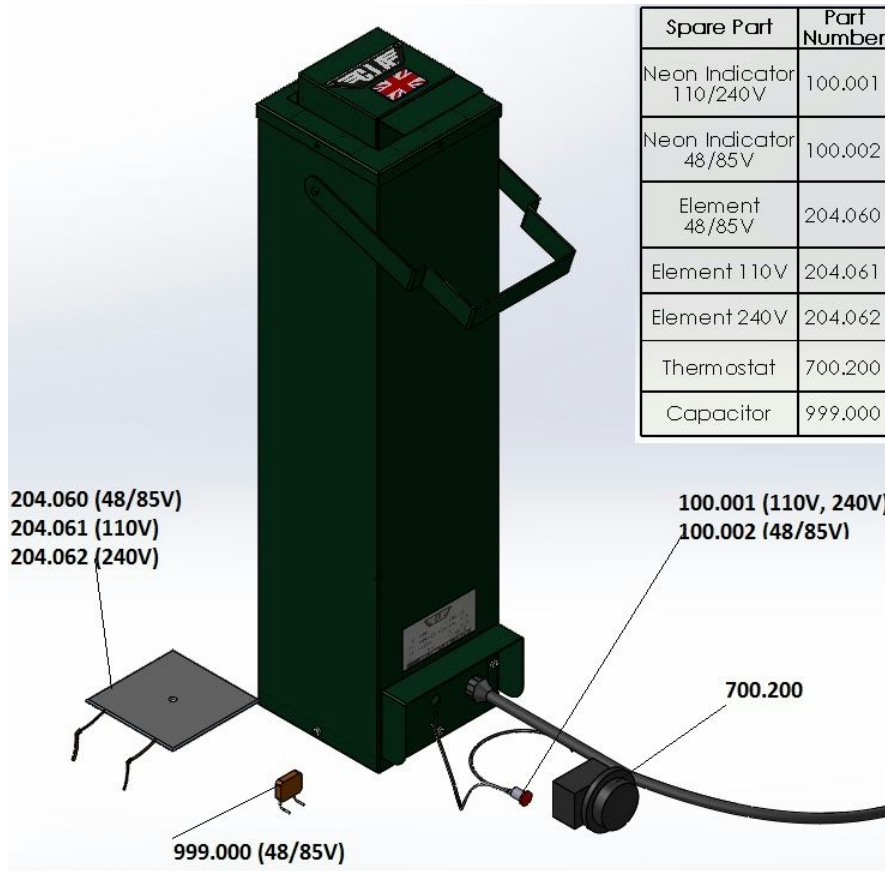

**CIA P8M2
110, 240V**

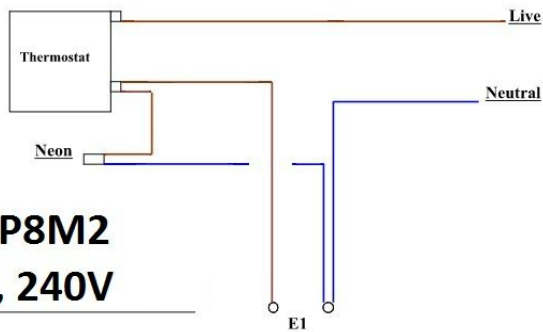

CIA P8M2 48/85V

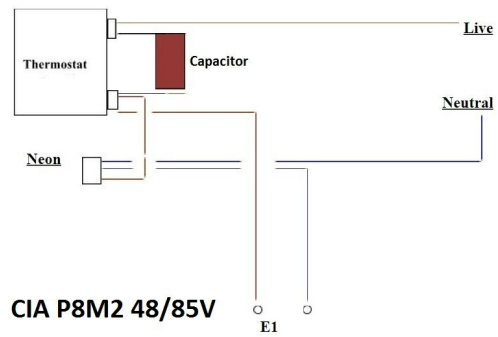

48/85V Versions are fitted with a capacitor between the thermostat terminals



CIA P15

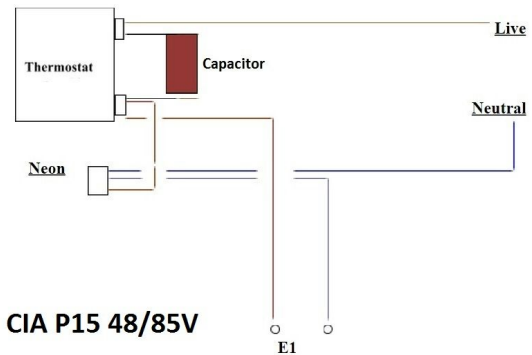
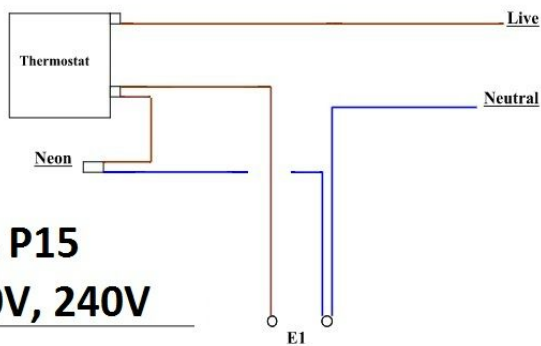
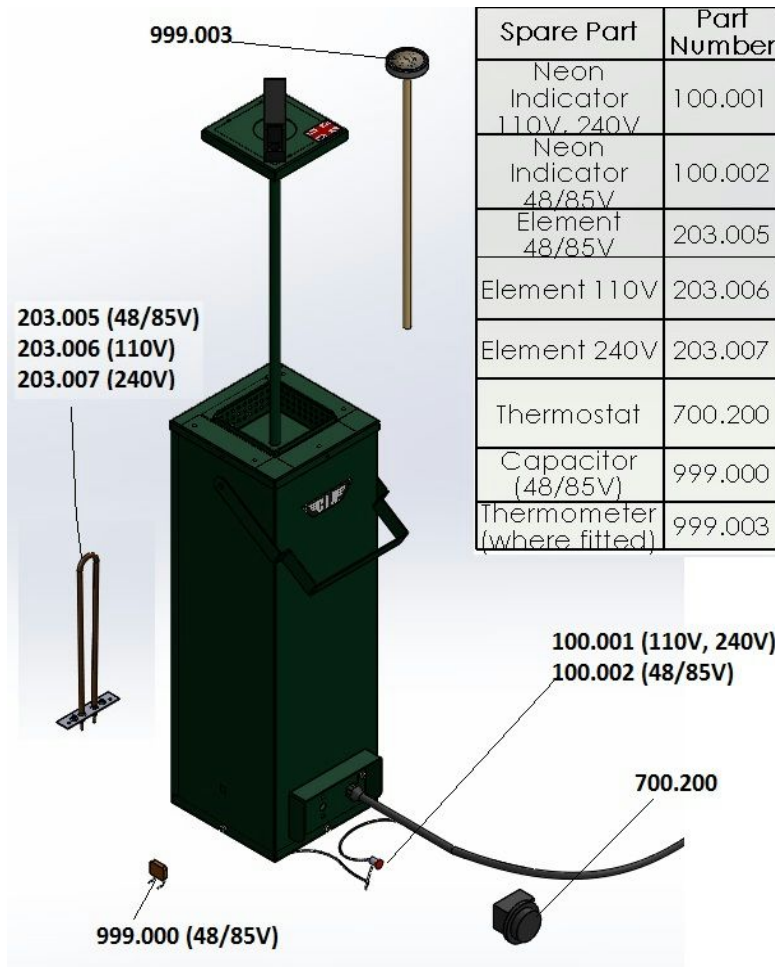

48/85V Versions are fitted with a capacitor between the thermostat terminals



CIA P15M2

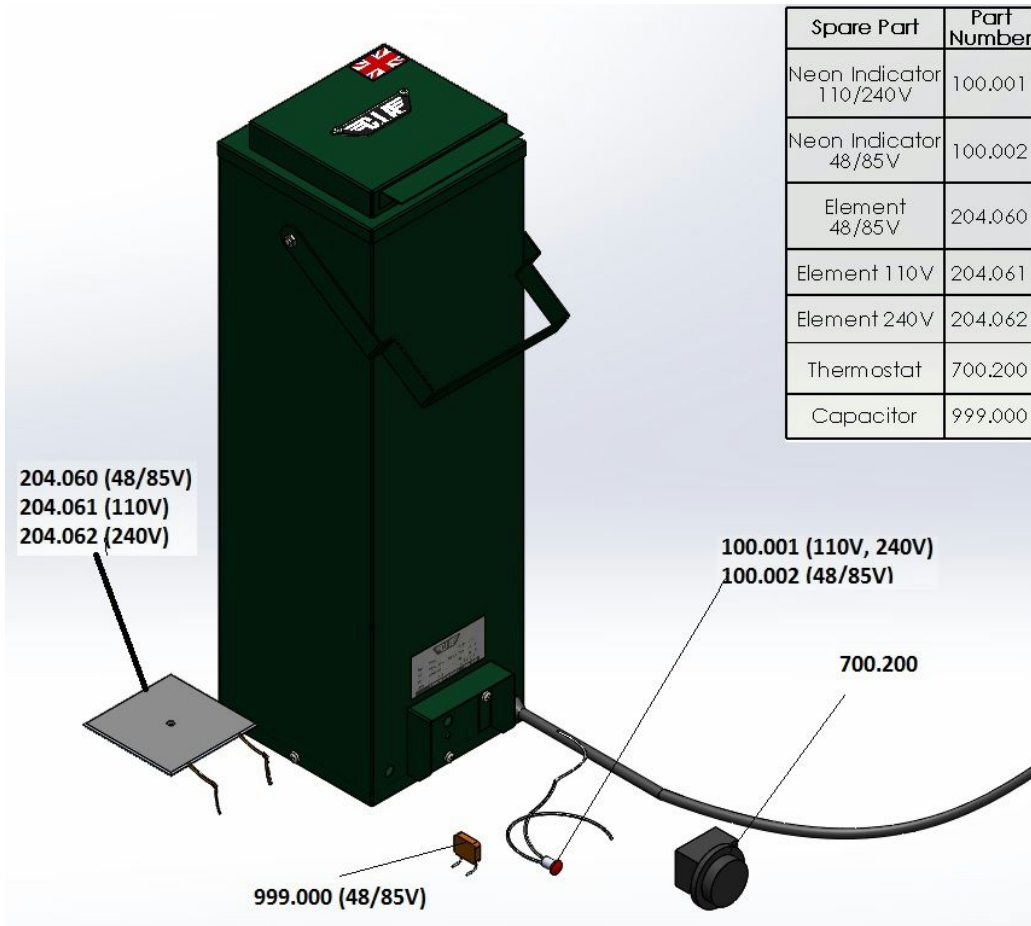

Spare Part	Part Number
Neon Indicator 110/240V	100.001
Neon Indicator 48/85V	100.002
Element 48/85V	204.060
Element 110V	204.061
Element 240V	204.062
Thermostat	700.200
Capacitor	999.000

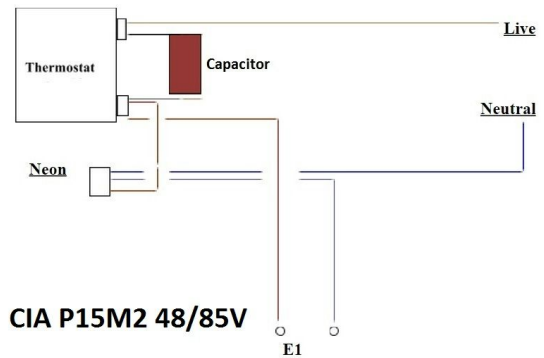
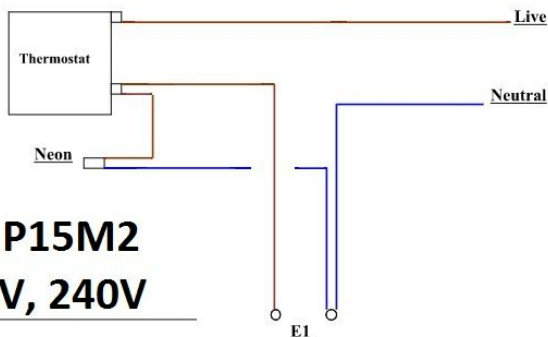

48/85V Versions are fitted with a capacitor between the thermostat terminals



CIA P16

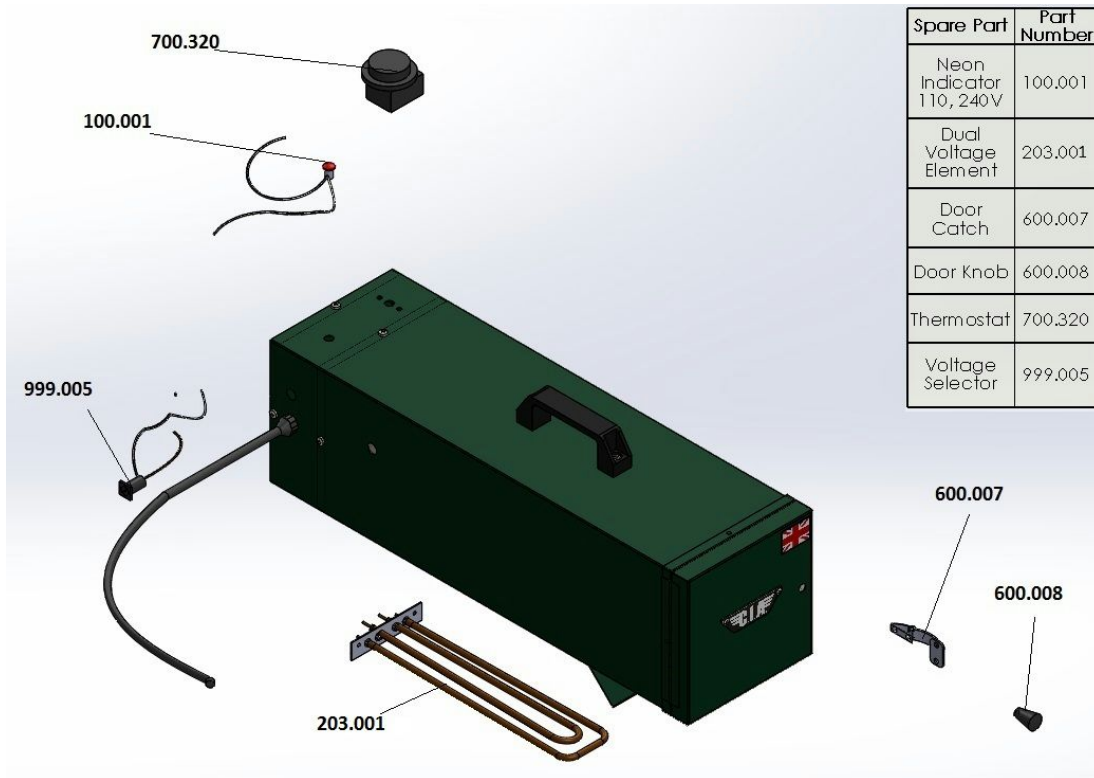

Spare Part	Part Number
Neon Indicator 110, 240V	100.001
Dual Voltage Element	203.001
Door Catch	600.007
Door Knob	600.008
Thermostat	700.320
Voltage Selector	999.005

CIA P16

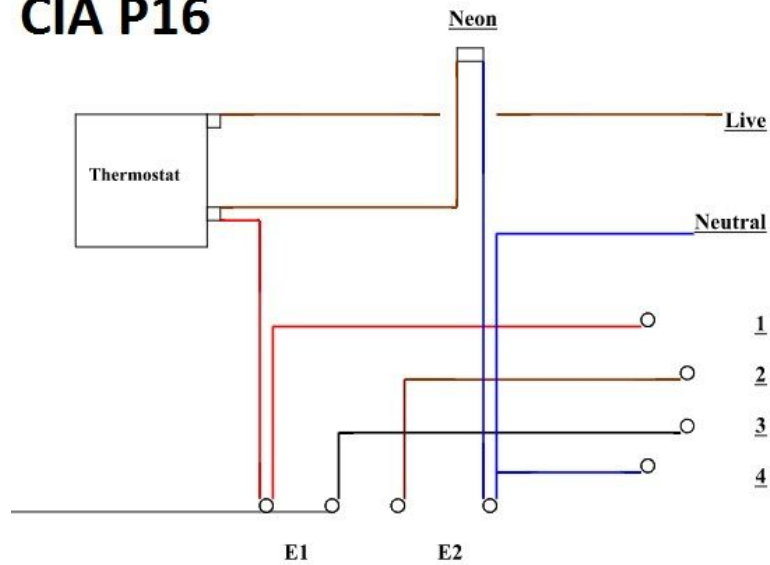



Item	Part Number	Item	Part Number
Neons		High Temp Elements	
Neon Indicator 110/240V	100.001	C2-C2P Element 1500Watt	205.030
Neon Indicator 48/85V Chrome Bezel	100.002	Thermocouple	
Neon switch 240V	100.003	Thermocouple Type K	300.004
Digital Controllers		Solid State Relay	
B1, B2, C1 Digital Controller	101.050	Solid State Relay (90-240V - 3-32Vdc) 40Amp	300.019
C2 Digital Controller	101.055	Door Parts	
C2P Digital Controller	101.060	Door Catch	600.007
Stationary Oven Elements		Door Knob (M6 Black Moulded Knob)	600.008
110V, 750Watt, 940mmx 6.5ø element	202.020	Door Seal Kit (Glass fibre tape + rivets)	600.009
240V 750W, 940mmx6.5ø element	202.021	Thermostats	
Quiver Elements		Thermostat Kit (120c)	700.120
110-240V Dual voltage element (P16)	203.001	Thermostat Kit (200c)	700.200
24V-150Watt 6.35ø element	203.002	Thermostat Kit (320c)	700.320
80V-200Watt 6.35ø element	203.003	Capacitors	
110V-150Watt 6.35ø element	203.004	Capacitor (48/85V versions only)	999.000
240V-150Watt 6.35ø element	203.008	Data Logger Kits	
48/85V-300Watt Element P8-P15	203.005	Data Logger	999.001
110V-300Watt Element P8-P15	203.006	Thermal Cut Out's	
240V-300Watt Element P8-P15	203.007	Thermal Cut out (24-48/85V Quiver only)	999.002
Dual voltage quiver element 110/240V 150W	203.009	Thermometers	
85V-275Watt 100x100 Square Element	204.060	0-250 Deg Thermometer	999.003
110V-275Watt 100x100 Square Element	204.061	32-500 Deg Thermometer	999.004
240V-275Watt 100x100 Square Element	204.062	Voltage Selectors	
		Voltage Selector Switch	999.005



Useful Information

<u>Model</u>	<u>Power (kW)</u>	<u>Capacity Kg</u>	<u>Internal dimensions (mm)</u>	<u>Shipping Weight Kg</u>
<u>P7</u>	0.15	9	121x115x460	3.3
<u>P8</u>	0.3	7	73x73x450	6
<u>P8M2</u>	0.275	7	73x73x450	5
<u>P15</u>	0.3	11	105x105x450	7
<u>P15M2</u>	0.275	15	105x105x450	7
<u>P16</u>	0.3	14	121x115x460	8

Warranty

General conditions

CIA guarantees the product mentioned in this manual for a period of 12 (twelve) months from the date of delivery. The warranty is valid for the above mentioned period and only for the parts that will have defect of design or defective material. CIA will give you further instructions for repairing or replacing the complained parts, free of charge. Any transport expenses will be covered by the customer.

Limitations

CIA Ovens Ltd **is not and will not be** responsible for:

- Improper use of the oven
- A use against the national and/or International regulations in force (where applicable)
- Improper or wrong connection
- Improper or insufficient care and maintenance
- Unauthorized modifications and/or services
- Use of non-original spare parts or non-specific components
- Partial or total Inobservance of the instructions



Declaration of *Conformity/Incorporation*

The electrical equipment which accompanies this declaration is in conformity with EU Directive(s)

2006/95/EC Low Voltage Directive

2004/108/EC Electromagnetic Compatibility Directive

CIA OVENS LTD

Unit 4, Station Road,
Furness Vale,
High Peak
United Kingdom

DIGITALLY CONTROLLED STATIONARY DRYING OVENS

Model P7, P8, P8M2, P15, P15M2, P16

The Technical Construction File is maintained at: CIA OVENS LTD.

Only for Declaration of Incorporation

This electrical equipment covered by this Declaration must not be put into service until the machinery into which it is to be incorporated has been declared in conformity with the provisions of the applicable Directive(s). This statement is only necessary where the product is to be incorporated into a machine or system.

The following harmonized standards have been used.

LVD	EMC <i>emission and immunity</i>
EN 60204-1:2006 - EN 60204-1:2006/A1:2009 EN 60529:1991 - EN 60529:1991/A1:2000 EN 60529:1991/AC:1993 EN 50525-1:2011 - EN 50525-2-11:2011 EN 50525-2-12:2011 - EN 50525-2-21:2011 EN 50525-2-71:2011	EN 61000-6-2:2005 - EN 61000-6-2:2005/AC:2005 EN 61000-6-3:2007 - EN 61000-6-3:2007/A1:2011 EN 61000-6-4:2007 - EN 61000-6-4:2007/A1:2011

The electrical equipment is CE-marked 2015.